

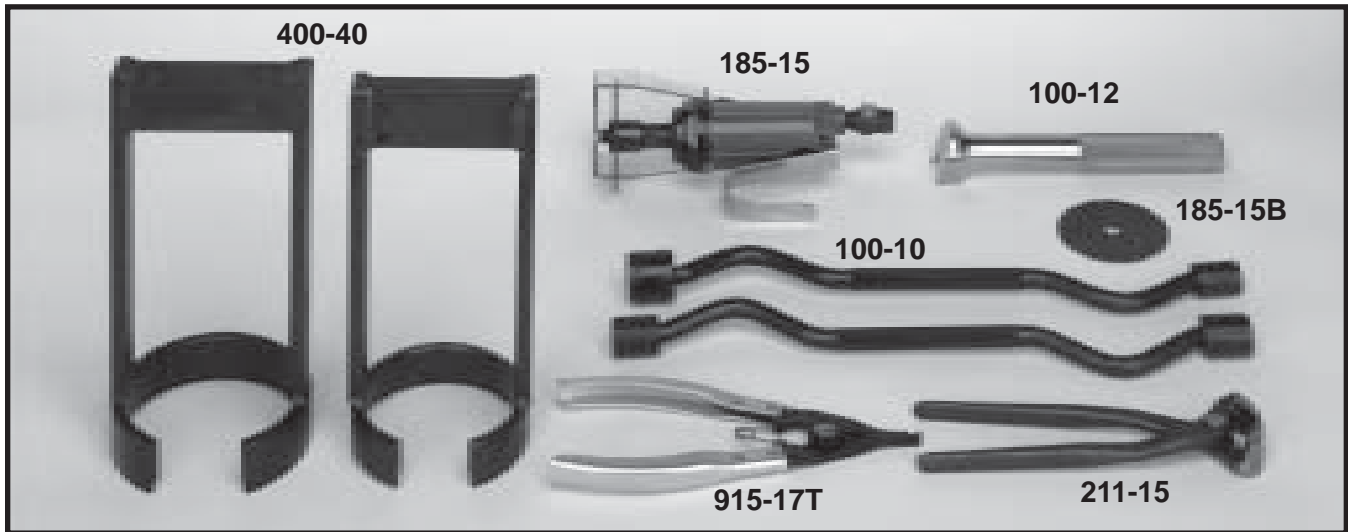

TOOL DESIGNS & APPLICATIONS

MANUFACTURER OF CONSTANT VELOCITY DRIVEAXLE COMPONENTS
1500 11TH AVENUE ROCKFORD, ILLINOIS 61104
PHONE (815) 962-1411 FAX (815) 962-4857
WEB SITE www.rockfordcv.com

Driveaxle Service Items



PART #	DESCRIPTION
100-10	CV Joint Bearing Removal Tool - Rotates The Race Allowing You To Remove The Bearings And Cage
100-12	Inner Race Driver - Aids In Removing Internal Clip Type Joints
185-15	Pneumatic Cut Off Tool - For Cutting Cage & Race Off Of Shaft
185-15B	Pneumatic Cut Off Tool Replacement Wheel
211-15	Side Cutters - For General Use
400-40	GM Boot Seal Ring Installer Set - Used To Remove And Install The Boot Retaining Rings Found On Many Early GM Axles
915-17T	Snap Ring Pliers - Use To Disengage Flat Faced Snap Rings



100-10
C.V. Joint Disassembly Tool: Fits All FWD

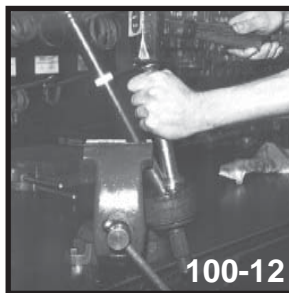

100-12
Inner Race Driver: For Removal of Joints With Frozen Internal Snap Rings

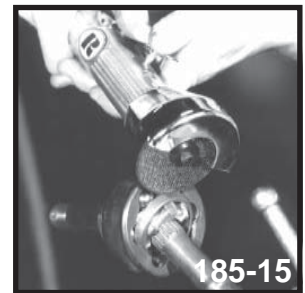

185-15
Pneumatic Cut Off Tool: Joint Removal When Internal Circlips Lock Joint On Shaft



211-15
Side Cutters: For General Use

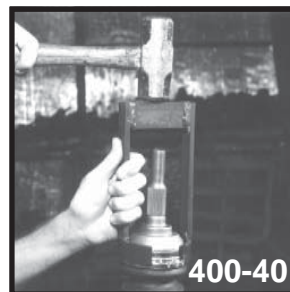

400-40
GM Boot Retainer Installer Set: Heavy Duty Construction

Polishing Materials

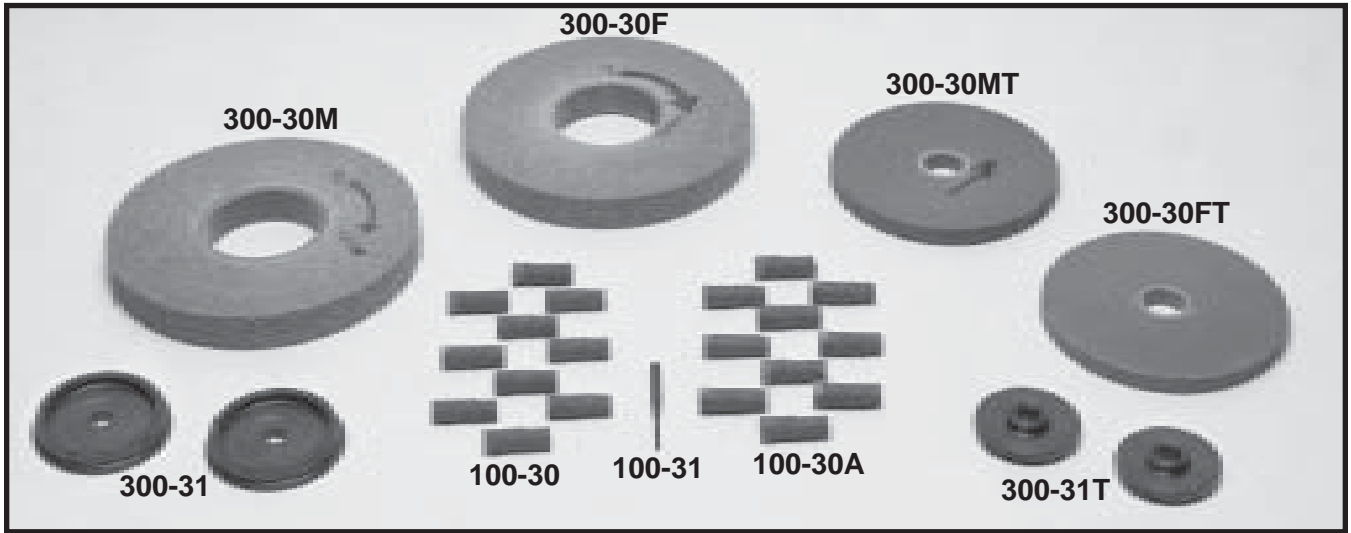

PART #	DESCRIPTION
100-30	Cartridge Rolls (Pkg of 10) - Fine - 120 Grit
100-30A	Cartridge Rolls (Pkg of 10) - Course - 60 Grit
100-31	Arbor For Cartridge Rolls
300-30F	Buffing Wheel - Fine 8" OD - 1" Thick
300-30FT	Buffing Wheel - Fine 6" OD - 1/2" Thick
300-30M	Buffing Wheel - Medium 8" OD - 1" Thick
300-30MT	Buffing Wheel - Medium 6" OD - 1/2" Thick
300-31	1/2" Arbor for 8" Wheel - (Set of Two)
300-31T	1/2" Arbor for 6" Wheel - (Set of Two)



Cartridge Roll & Arbor Assembly: For Polishing Ball Wear in Joints



Buffing Wheel & Arbor Assembly: For Polishing Ball Wear in Races

Banding & Clamping Materials

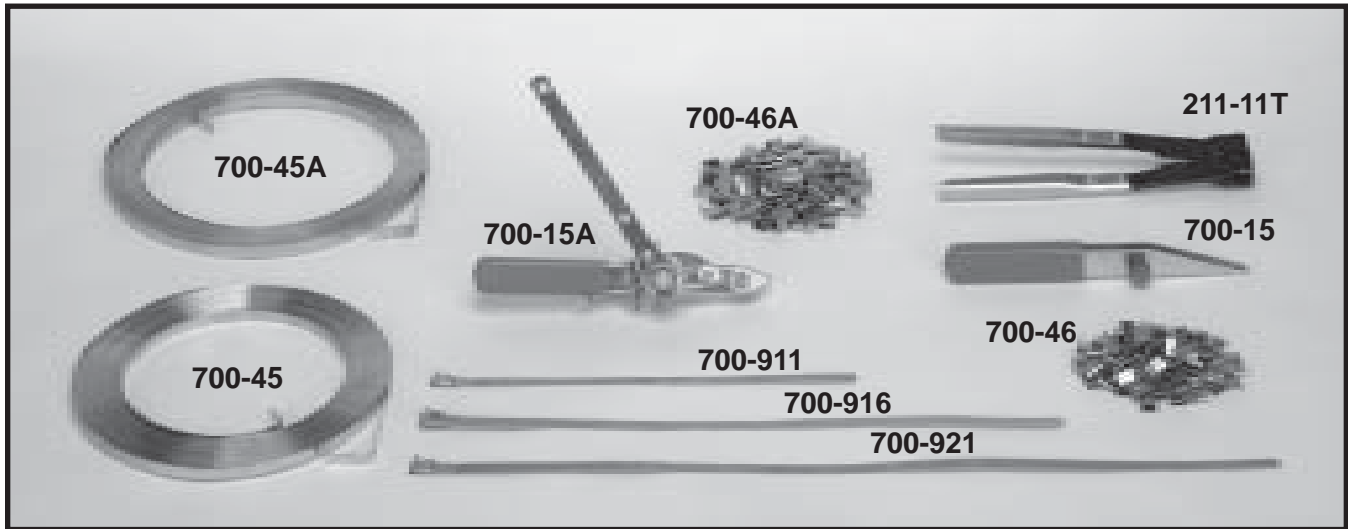

PART #	DESCRIPTION
211-11T	Banding Tool - Used For Crimp Type Clamps
700-15	Banding Tool - Used For Strap Type Clamps
700-15A	Banding Tool (Ratchet Design) - Used For Strap Type Clamps
700-45	Stainless Steel Band - 100' Roll, 5/16" Wide
700-45A	Stainless Steel Band - 100' Roll, 3/8" Wide
700-46	Steel Band Clips - Pkg Of 100 Fits 5/16" Wide Band
700-46A	Steel Band Clips - Pkg Of 100 Fits 3/8" Wide Band
700-911	Band Straps - 11" Long, 5/16" Wide (Pkg Of 6)
700-916	Band Straps - 16" Long, 3/8" Wide (Pkg Of 6)
700-921	Band Straps - 21" Long, 3/8" Wide (Pkg Of 6)



700-15
Banding Tool: For Strap Type Clamps



211-11T
Banding Tool: For Crimp Type Clamps

Axle Shaft Removal and Installation Items

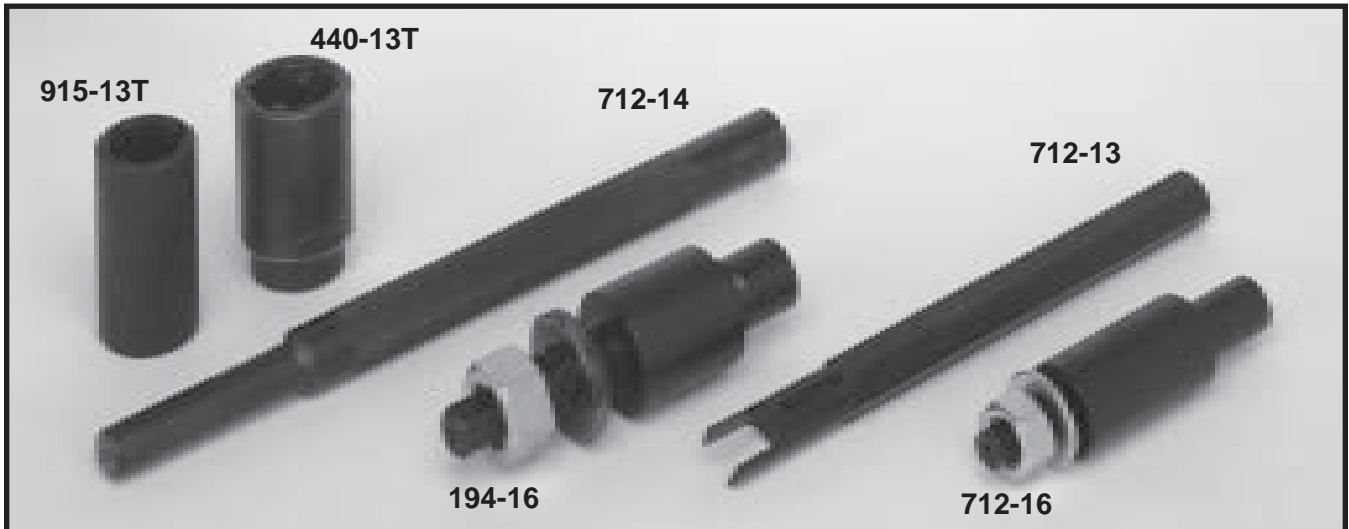

PART #	DESCRIPTION
194-16	Hub Installer Tool - Pulls The CV Thru The Hub On Subaru's
440-13T	Deep Well Socket - 36mm
712-13	Shaft Removal Tool - Allows You To Remove The Drivers Side Shaft Thru The Transaxle On Ford Applications
712-14	OB Joint Punch - Remove The Joint From Hubs W/O Damaging The Stub (Ford And Subaru Applications)
712-16	Hub Installer Tool - Pulls The CV Thru The Hub On Ford's
915-13T	Deep Well Socket - 30mm

Crossgroove Assembly Tools



PART #	DESCRIPTION
100-21T	Crossgroove Assembly Tool Set
100-21TA	Crossgroove Assembly Tool - Beretta
100-21TB	Crossgroove Assembly Tool - Lemans Auto
100-21TC	Crossgroove Assembly Tool - Lemans Man & Bravada

Axle Shaft Removal and Installation Items

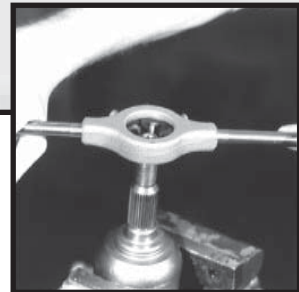

PART #	DESCRIPTION
200-20	Thread Die Set - Includes Holder & 11 Solid Dies
200-20S	Thread Die Set - Includes Holder & 11 Split Dies
200-20A	Die (26 x 1.25mm) - GM (Eldorado & Toronado 67-78)
200-20AS	Split Die (26 x 1.25mm) - Same as Above
200-20B	Die (24 x 1.5mm) - Acura CL, (Legend 87-90) & Vigor, AMC Eagle, GM (Eldorado & Toronado 79-85), Honda (Accord & Prelude 90-up), Nissan (Stanza & Maxima 87-up), Subaru (exc. SVX, XT6 & Justy)
200-20BS	Split Die (24 x 1.5mm) - Same as Above
200-20C	Die (22 x 1.5mm) - Acura Integra, Audi 100 & 5000, BMW, Chrysler Domestic (exc. LH Body) & Imports, Diahatsu, Ford Contour, (Escort 92-96), Explorer, (Probe 88-98), T-Bird, Honda (Accord & Prelude 72-89), (Civic 80-98), Hyundai, Infinity G20, Kia Sephia, Lexus ES300, Mazda (MX6, Protege, 626 88-98), Mitsubishi, Nissan (Altima, Pulsar, Sentra 87-97), Saab 9000, Subaru Forester, Legacy, Impreza, SVX & XT, Toyota Paseo & Previa
200-20CS	Split Die (22 x 1.5mm) - Same as Above
200-20D	Die (20 x 1.5mm) - Audi (exc. 5000), Eagle Medallion & Premier, Ford Aspire, Festiva, Probe 83-87, Taurus, Tempo & Windstar, GM With 3/4" Thread Dia 80-99, Mazda (MX6 & 626 83-87), Renault, Subaru Justy 89-94, Volkswagen
200-20DS	Split Die (20 x 1.5mm) - Same as Above
200-20E	Die (24 x 2.0mm) - GM With 1" Thread Dia 82-99 Including 4x4 Trucks
200-20ES	Split Die (24 x 2.0mm) - Same as Above
200-20F	Die (19 x 1.5mm) - Toyota Camry, Celica, Corolla & Tercel
200-20FS	Split Die (19 x 1.5mm) - Same as Above
200-20G	Die (22 x 1.0mm) - Datsun 310/F10, Mazda 929, Nissan (Pulsar, Sentra, Stanza 82-86)
200-20GS	Split Die (22 x 1.0mm) - Same as Above
200-20H	Thread Die Holder - Handle Only
200-20I	Die (18 x 1.5mm) - Chevy Metro & Sprint, Geo Metro, Subaru Justy 87-88, Suzuki Swift
200-20IS	Split Die (18 x 1.5mm) - Same as Above
200-20J	Die (20 x 1.0mm) - GM LeMans & Spectrum, Geo Storm, Isuzu I-Mark, Impluse & Stylus
200-20JS	Split Die (20 x 1.0mm) - Same as Above
200-20K	Die (27 x 2.0mm) - Chrysler LH Body, GM (C Body & H Body 91-95)
200-20KS	Split Die (27 x 2.0mm) - Same as Above
200-20L	Die (26 x 1.5mm) - Acura Legend 91-95
200-20LS	Split Die (26 x 1.5mm) - Same as Above

Benchwork Tools: Air Vice

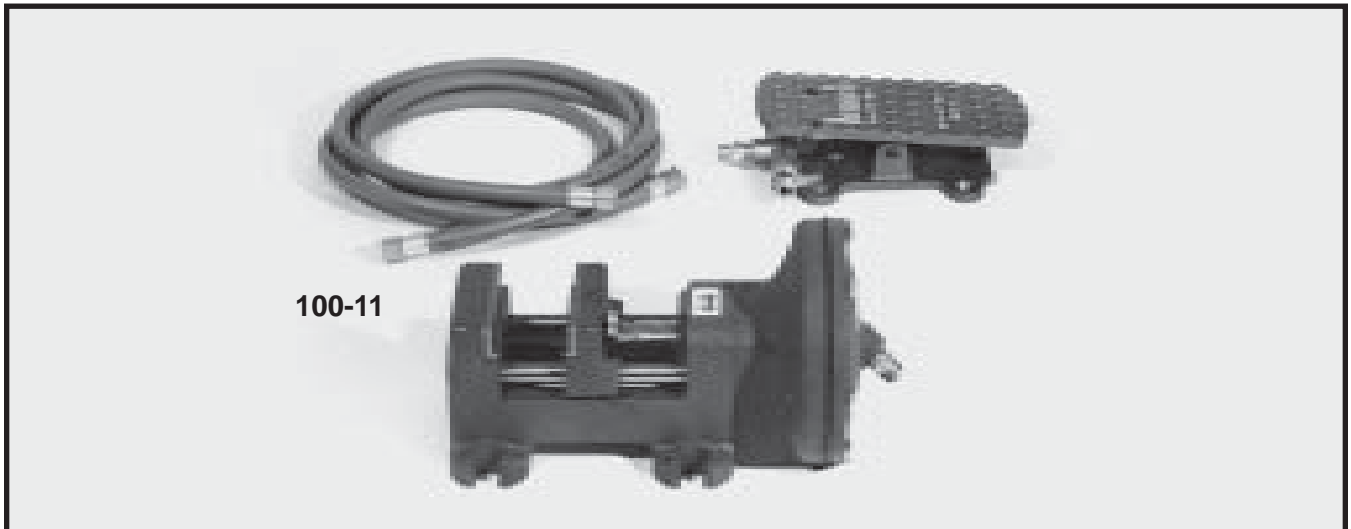

PART #	DESCRIPTION
100-11	Pneumatic Air Vice - (Foot pedal allows for hands free operation)

Benchwork Tools: Bushing Driver



PART #	DESCRIPTION
176-E6	Disk Joint Bushing Installer/Remover - (Toyota Previa Equipment Drive Shafts)

Benchwork Tools: Seal Driver

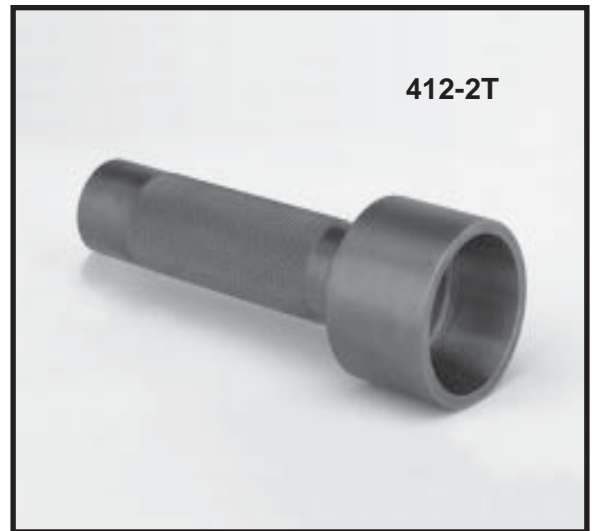

PART #	DESCRIPTION
412-2T	Seal Driver - for Late Model Spicer Design Stud Yokes - (Use On 412-2 Dust Shield)

Benchwork Tools: Crimping Fixtures & Repair Parts

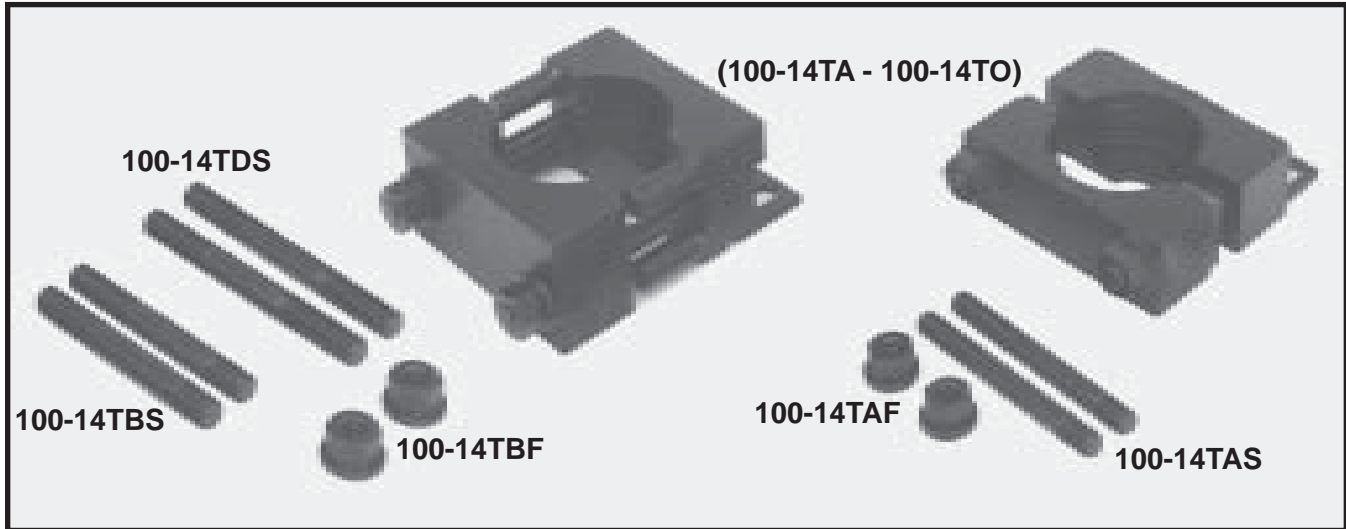

PART #	DESCRIPTION
100-14TA	Crimping Fixture - ACI Chrysler, ACI Ford Tempo (214-15 Boot Flange)
100-14TAF	Replacement Flange Nut (Ea.) - Fits 1/2" Stud
100-14TAS	Replacement Stud (Ea.) - 1/2" x 5"
100-14TB	Crimping Fixture - Pontiac LeMans RH Auto Trans (712-3A Boot Assembly)
100-14TBF	Replacement Flange Nut (Ea.) - Fits 5/8" Stud
100-14TBS	Replacement Stud (Ea.) - 5/8" x 5"
100-14TC	Crimping Fixture - Pontiac LeMans Manual Trans (712-4A Boot Assembly)
100-14TD	Crimping Fixture - Nissan 300ZX Non-Turbo (280-4 Boot Assembly)
100-14TDS	Replacement Stud (Ea.) - 5/8" x 6"
100-14TE	Crimping Fixture - Mercedes Benz (230-4 Boot Assembly)
100-14TF	Crimping Fixture - Ford Taurus ACI, Mercury Sable ACI (715-15 Boot Flange)
100-14TG	Crimping Fixture - Chevrolet Camaro, Oldsmobile Bravada, Pontiac Firebird (421-10A & 421-10C Boot Assemblies)
100-14TH	Crimping Fixture - BMW 318i, BMW 325e (320-AS Boot Flange)
100-14TI	Crimping Fixture - Lincoln Continental (714-4AS Boot Flange)
100-14TJ	Crimping Fixture - Lexus GS300, LS400, SC300 & SC400 (550-4AS Boot Flange)
100-14TK	Crimping Fixture - Mercedes Benz (220-3AS Boot Flange)
100-14TL	Crimping Fixture - BMW 3 Series (804-4AS Boot Flange)
100-14TM	Crimping Fixture - Ford Thunderbird, Mercury Cougar (716-15 Boot Flange)
100-14TN	Crimping Fixture - BMW Lineshafts 99mm Joints (804-10A Boot Assembly)
100-14TO	Crimping Fixture - Jeep Grand Cherokee Lineshafts (424-3AS Boot Flange & 424-15 End Cap) <u>Crimps Both Pcs in One Step</u>
100-14TP	Crimping Fixture - Buick Rainer, Chevy Astro Van, Blazer, Trailblazer, S-10 Pickup, GMC Envoy, Jimmy, Safari Van, S-15 Pickup, Isuzu Ascender, Hombro & Oldsmobile Bravada (429-10A Boot Assembly)
100-14TQ	Crimping Fixture - Jeep Grand Cherokee, Liberty, Dodge Dakota, Durango -Rear Joints (361-80 & 361-80D Joint Assembly)
100-14TR	Crimping Fixture - Jeep Grand Cherokee & Liberty - Front Joints (361-80B Joint Assembly)

Extra Service Items

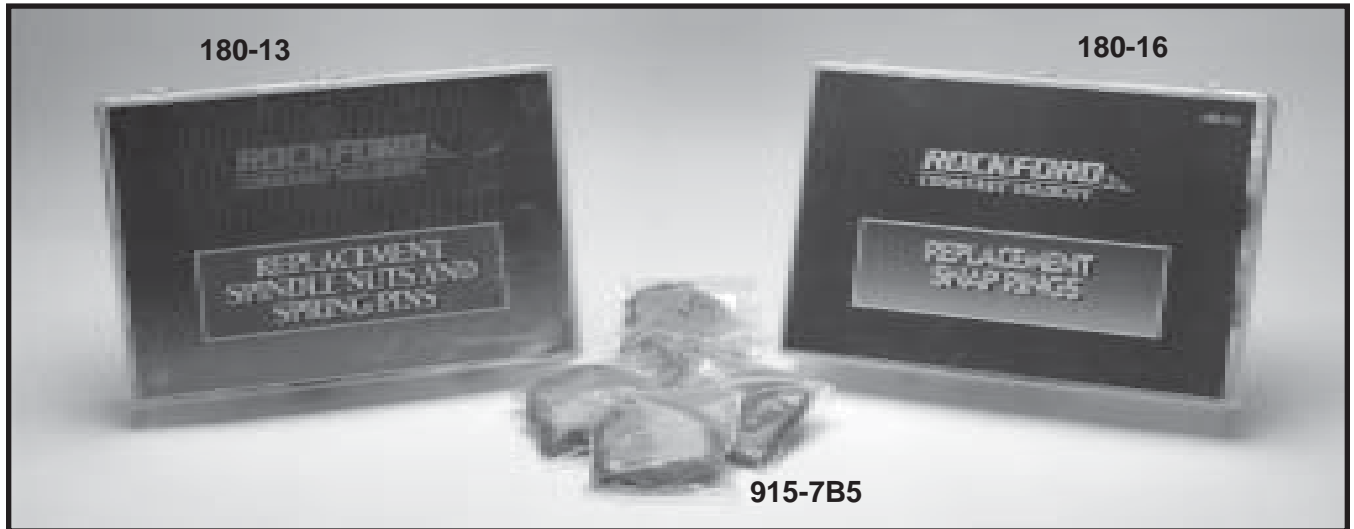

PART #	DESCRIPTION
180-13	Replacement Spindle Nut & Spring Pins Kit - Assortment of 17 Spindle Nuts & Spring Pins (194-14, 271-12 & 275-14 Pins, 163-13C, 163-13S, 164-13, 184-12, 194-13, 195-13, 213-13, 440-13, 441-13, 536-13, 712-12, 813-13 & 915-13 Spindle Nuts) in a durable storage box
180-16	Replacement Snap Ring Kit - Assortment of 18 popular internal snap rings (161-16, 163-16, 164-16, 174-16, 178-16, 184-16, 185-17, 211-16, 213-16, 214-17, 215-16, 275-16A, 536-17, 615-17, 625-15, 626-16, 627-16, 628-16, 713-17, 714-17, 716-16, 813-17A & 813-17) in a durable storage box
915-7B5	C.V. Joint Grease - 3.5 oz. Ea. (Pkg. of 5)
915-7B	C.V. Joint Grease - 3.5 oz. Ea. (Individual Packs)

C.V. Driveaxle Grease: Dura-Grease & Pump Materials

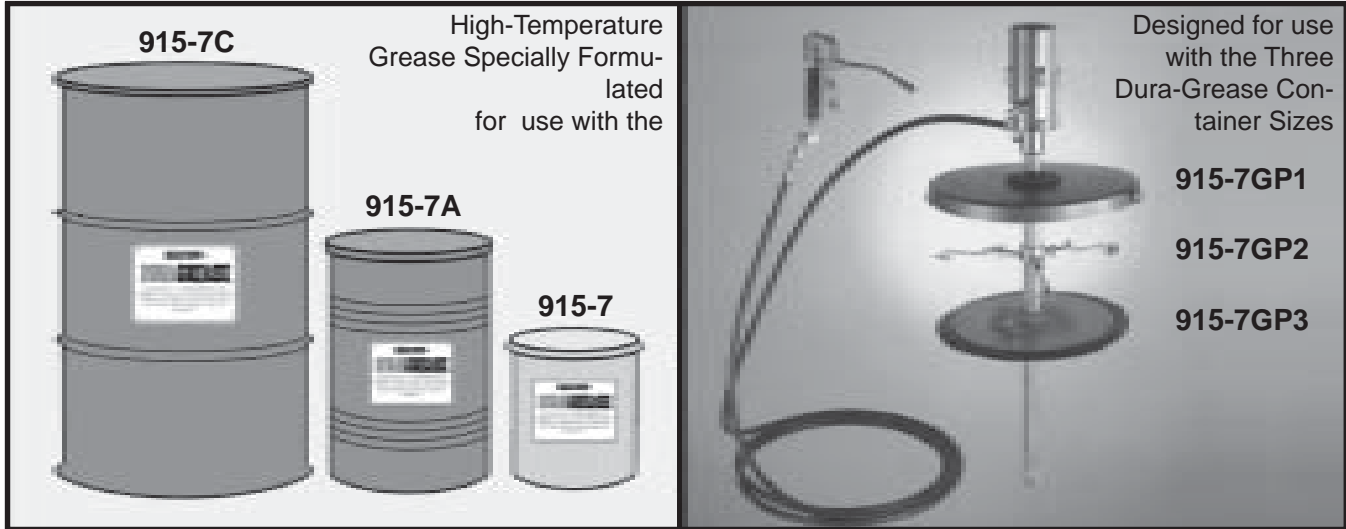

High-Temperature Grease Specially Formulated for use with the

Designed for use with the Three Dura-Grease Container Sizes

PART #	DESCRIPTION
915-7	C.V. Joint Dura-Grease - 35 Lbs.
915-7A	C.V. Joint Dura-Grease - 120 Lbs.
915-7B	C.V. Joint Dura-Grease - 3.5 Oz. Bag (Not Pictured)
915-7C	C.V. Joint Dura-Grease - 400 Lbs.
915-7GP1	Grease Pump - Fits 400 Lbs. Barrels
915-7GP2	Grease Pump - Fits 120 Lbs. Barrels
915-7GP3	Grease Pump - Fits 35 Lbs. Buckets
915-7GPG	Replacement Grease Pump Gun - (Not Pictured)
915-7GPH	Replacement Grease Pump Hose - (Not Pictured)
915-7GPK	Extra Gun Kit - (Not Pictured)
915-7GPZ	Replacement Grease Pump "Z" Swivel - (Not Pictured)

Driveaxle Boxes : For Shipping Axles To Your Customers



PART #	DESCRIPTION
BX23	25 Driveaxle Boxes - 23" x 6" x 6"
BX36	25 Driveaxle Boxes - 36" x 4" x 5"
BX43	25 Driveaxle Boxes - 43" x 4" x 5"